

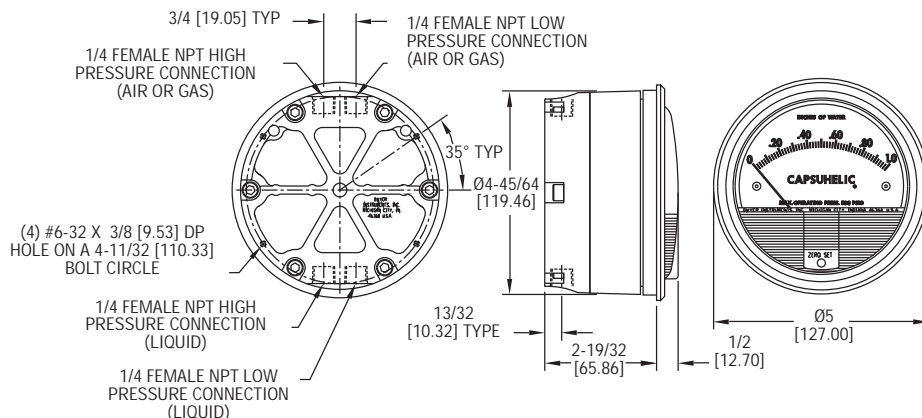

## Series 4000 Capsuhelic® Differential Pressure Gage

### Specifications - Installation and Operating Instructions



**CAUTION:** Use of a line filter (Dwyer Instruments, Inc. model A-391 or equivalent) is recommended to prevent entry of liquid borne particles into gage. Dwyer Instruments, Inc. cannot assume responsibility for failure of gages due to clogging of internal passages.

**Note:** May be used with hydrogen where pressures are less than 35 psi. Order with Buna-N diaphragm.

#### CAPSUHELIC® GAGE INSTALLATION

1. Select a location free from excessive vibration and where the ambient temperature will not exceed 200°F. Sensing lines may be run any necessary distance. For example, 250 foot lines will not affect accuracy but will damp the reading slightly. Do not restrict lines. If pulsating pressures or vibration cause excessive pointer oscillation, consult factory for means of providing additional damping.

2. All standard models are calibrated for use with the diaphragm and scale in a vertical position. Special factory calibration is necessary for operation in an inclined or horizontal position. The exceptions are ranges under 5 in. w.c., (or metric equivalents) which can only be calibrated for vertical operation.

#### SPECIFICATIONS

**Service:** Aluminum Case: Air and compatible gases and oil based liquids. Brass Case: Air and compatible gases and water based liquids.

**Wetted Materials:** Consult factory.

**Housing:** Die cast aluminum with impregnated hard coating, standard. Optional forged brass housing is required for water or water based fluids. Special material diaphragms available, contact factory.

**Accuracy:** ±3% of full scale at 70°F (21.1°C). (±2% on 4000S models, ±4% on 4200, 4210, 4215, 4220, 4300, 4400, and 4500).

**Pressure Limits:** -20" Hg to 500 psig. (-0.677 bar to 34.4 bar).

**Temperature Limits:** 20 to 200°F. (-6.67 to 93.3°C).

**Size:** 4" (101.6 mm) diameter dial face.

**Mounting Orientation:** Diaphragm in vertical position. Consult factory for other position orientations.

**Process Connections:** 1/4" female NPT high and low pressure taps, duplicated -one pair top for air and gas, and one pair bottom for liquids.

**Weight:** 3 lb, 3 oz (1.45 kg) aluminum case; 7 lb, 13 oz (3.54 kg) brass case.

**Standard Accessories:** Two 1/4" NPT plugs for duplicate pressure taps, four flush mounting adapters with screws and four surface mounting screws.

### 3. Surface Mounting

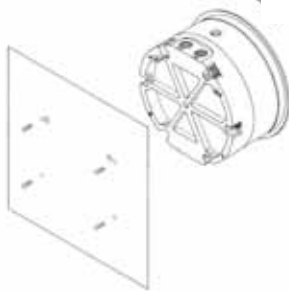
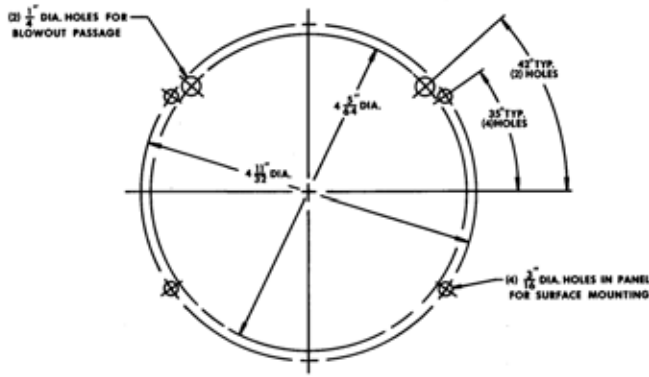

Locate 4 mounting holes, 35° from horizontal centerline on a 4-11/32" dia. circle. Use No. 6-32 machine screws of appropriate length. Be sure to drill 1/4" holes for blowout protection as shown in the diagram.

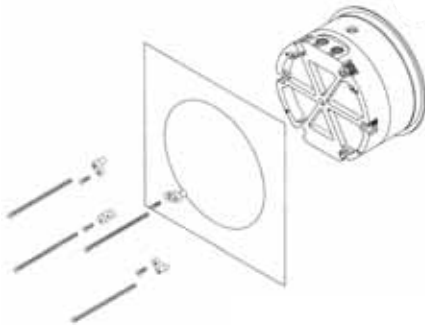

### 4. Flush Mounting

Provide a 4-13/16" dia. opening in panel. Insert gage and secure in place with No. 6-32 machine screws of appropriate length, with mounting lugs firmly secured in place.

### 5. To zero the gage after installation

Set the indicating pointer exactly on the zero mark, using the external zero adjust screw on the cover at the bottom. Note that the zero check or adjustment can only be made with the high and low pressure taps both open to atmosphere.

### CAUTION

Note location of blowout or vent holes in the surface mounting diagram. Do not block these holes as their function is to vent overpressure failure out the back of the gage rather than blowing off the front cover.

### Important Notes:

Two pairs of high and low pressure taps are provided, one pair on the top and a duplicate pair on the bottom. These fittings may be utilized according to the type of service for which the gage will be used. For gas or vapor service the gage should be connected from the pressure source to the top pressure fittings so that any accumulation of condensate may be drained or bled out the bottom fittings. For liquid service the pressure source should be connected to the bottom taps so that any trapped gas may be vented out the top fittings. Optional bleed fittings may be obtained to replace the standard 1/4" NPT plugs for installations requiring frequent draining or venting of the gage. Note that the unused pair of pressure taps must be plugged in order for the gage to operate. For straight pressure or vacuum applications where only one of a pair of high and low pressure taps are being utilized, the other tap must be open to atmosphere.

For portable use or temporary installation use 1/4" male NPT to male flare fitting and connect to pressure source with high pressure hose or tubing with flare nut connectors.

For permanent installation 1/4" OD copper or stainless steel tubing is recommended.

Proper installation of fittings and plugs is important. Sparingly apply pipe thread sealant to threads. Excessive amounts can fall into pressure passages and cause blockage. We recommend Loctite® 69-31 Hydraulic Sealant. Install using torque wrench. Tighten only to 20 ft/lbs. Over-tightening can damage case.

### MAINTENANCE

Upon final installation of the Series 4000 Capsuhelic® Differential Pressure Gage, no routine maintenance is required. The Series 4000 is not field serviceable and should be returned if repair is needed (field repair should not be attempted and may void warranty). Be sure to include a brief description of the problem plus any relevant application notes. Contact customer service to receive a return goods authorization number before shipping.

Loctite® is a registered trademark of Henkel Corporation and Company.